

STATUS OF THE ANTIPROTON DECELERATOR AND OF THE ELENA PROJECT AT CERN

P. Belochitskii, CERN, Geneva, Switzerland

Abstract

The Antiproton Decelerator (AD) at CERN operates for physics since 2000 [1]. It delivers low energy antiprotons for production and study of antihydrogen, for atomic physics and for medical research. Two beam cooling systems, stochastic and electron, play key roles in AD operation. They make beam transverse and longitudinal emittances small, which is an obligatory condition for beam deceleration without losses, as well as for physics. The machine performance is reviewed, along with plans for the future. Significant improvement of intensity and emittances of the beam delivered to the experiments could be achieved with the addition of a small ring suitable for further deceleration and cooling. The details of this new extra low energy antiproton ring (ELENA) and its status are presented.

AD CYCLE

The 26 GeV/c proton beam from CERN PS is delivered to the target where antiprotons are produced and transferred to AD. The machine cycle is a sequence of plateaus and ramps (Figure 1). The first plateau is suited for injection of 4 bunches followed by 90° rotation in the longitudinal phase space to fit beam momentum spread to longitudinal acceptance of the stochastic cooling system. Then beam is cooled, decelerated down to 2 GeV/c and cooled again. Deceleration down to 300 MeV/c follows, where beam is cooled, now with electron cooling. Next ramp down to 100 MeV/c follows, where beam is cooled down to emittances required for AD experiments, bunched and extracted.

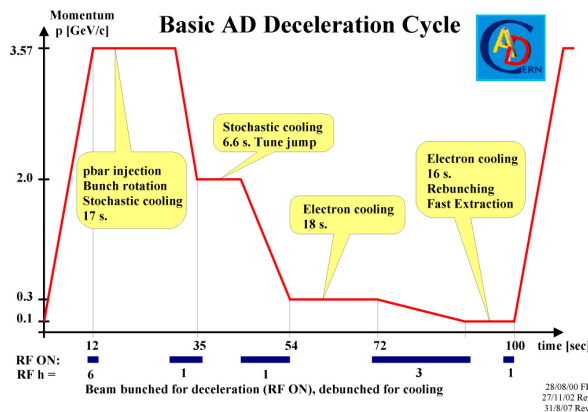

Figure 1: AD cycle.

STOCHASTIC COOLING

Due to lack of space only band I (1 - 1.65 GHz) from AC (AD predecessor) is used (H&V pickup tanks and H&V kicker tanks), bands II and III (1.65 GHz to 2.40 GHz and 2.40 GHz to 3.0 GHz) are dismantled. The momentum

cooling is done by notch filter method with sum signal from both PUs sent to both kickers. The momentum acceptance of system is about $\pm 1.0\%$, which is significantly smaller than momentum spread of injected beam which is $\pm 3\%$. To fit the latter to the former, the advantage of short bunch length of production beam is used. Short antiproton bunches are rotated 90° in the longitudinal phase space with reduction of momentum spread to about $\pm 1.2\%$. Cooling at 2 GeV/c is mainly aimed to reduce momentum spread of beam to fit the small longitudinal acceptance of RF cavity. The performance of stochastic cooling system is shown in Table 1.

Table 1: Performance of stochastic cooling system

Momentum, GeV/c	3.57	2.0
Duration, sec	17	6
$\epsilon_x / \epsilon_y, \pi$ mm mrad	3 / 3	4 / 5
$\Delta p/p$	$1 \cdot 10^{-3}$	$2 \cdot 10^{-4}$

ELECTRON COOLING

The AD electron cooler (Figure 2) is recuperated from LEAR, which stopped operation in 1996, with minimal upgrade (mechanical support, change from S-shape to U-shape). The parameters of cooler are given in Table 2.

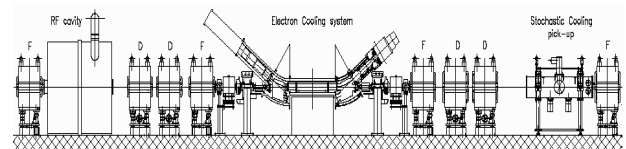

Figure 2: Layout of electron cooler.

The performance of electron cooling in AD is sensitive to orbit stability. Special procedure has been implemented to compensate slow orbit drift caused by decay of eddy currents in massive end plates of bending magnets. To avoid losses during cooling process, careful choice of tunes and coupling compensation have to be done.

Table 2: Main parameters of electron cooler

Cooling length, m	1.5
Electron beam energy, keV	2.8 - 35
Electron beam current, A	0.1 - 2.5
Field in solenoid, Gs	590
Electron beam radius, cm	2.5

The electron cooling at 300 MeV/c is accompanied by about 13% of beam losses. They can be reduced by earlier start of gun voltage, several seconds before beam arrives to plateau. In addition, both careful choice of tunes and coupling compensation have to be done to keep as much beam as possible during cooling.

Small dispersion in a cooler region is prepared at 300 MeV/c resulting in a smaller horizontal emittance compared with the vertical one. The cooling time at 300 MeV/c is about 10 sec to 15 sec. It is chosen to cool down to emittances less than 5π mm mrad in both planes to make the following deceleration lossless and also to facilitate cooling at 100 MeV/c.

Main task of cooling at 100 MeV/c is to prepare the beam for physics. Typical requirements are: $\epsilon < 1\pi$ mm mrad and bunch length shorter than 170 nsec. Due to RF noise during beam bunching before extraction the longitudinal emittance is blown up resulting in increased bunch length. To overcome this, electron cooling is extended to overlap a part of bunching process. Unfortunately, the “cross-talk” between two systems causes beam filamentation in transverse planes with creation of core (70% to 85% of beam) and halo [2]. The compromise for overlapping time for cooling and bunching has to be carefully chosen to achieve optimal transverse and longitudinal emittances. The performance of electron cooling is given in Table 3.

Table 3: Performance of electron cooling

Momentum, MeV/c	300	100
Duration, sec	16	15
$\epsilon_x / \epsilon_y, \pi$ mm mrad	1.6 / 2.4	<0.5 / <0.5
$\Delta p/p$	$8 \cdot 10^{-5}$	$1.2 \cdot 10^{-4}$

MACHINE OPERATION

Since autumn 2004 AD runs without stopping on weekends to increase a time available for physics. In 2006 beam availability went down to 70% due to major faults in CERN PS and due to long start up period in AD. This year is good in view of machine performance. Unfortunately in the middle of the run the orbit started to jump from time to time causing degradation of deceleration efficiency and emittance until new readjustment. This is caused by magnetic field fluctuations in one of the dipoles on side of electron cooler. The coils in this corrector magnet are likely to be damaged and the magnet is scheduled for replacement. The operational statistics is summarized in Table 4.

Table 4: Operational statistics

	2000	2001	2002	2003	2004	2006
Total	3600	3050	2800	2800	3400	2352
Physics	1550	2250	2100	2300	3090	2185
MD	2030	800	700	500	310	167
Uptime	86%	89%	90%	90%	71%	69%

MACHINE PERFORMANCE

The performance of AD is defined by number of antiprotons per second and by beam emittances. The deceleration efficiency (number of extracted antiprotons divided by number of cooled antiprotons at injection energy) is 80% to 85% and can be improved only slightly.

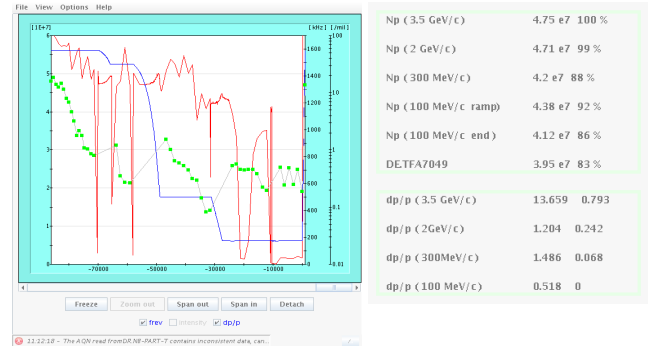

Figure 2: Beam intensity during AD cycle.

The beam intensity depends mainly on production beam from CERN PS. The potential of its increase exists but needs hardware upgrade for sophisticated RF gymnastics in PS. The ramp speed is limited by eddy currents and is already at the limit. The cooling time at 100 MeV/c could be shorter which is a subject for investigations.

Yet there is another and very efficient way to increase a lot the number of antiprotons delivered to experiment. To present this proposal a short review is useful which gives more details how AD beam is used by experiments.

POSTDECELERATION OF AD BEAM BY EXPERIMENTS

The ALPHA and ATRAP experiment physics programs are focused on trapping antiprotons in Penning traps where antihydrogen is created after recombination with positrons. Typical energy range to trap antiprotons is 3 keV to 5 keV. To decelerate beam down to this range from extraction energy 5.3 MeV (momentum 100 MeV/c) several degraders are used. During passing the degrader 99.9% of AD beam is lost and the remaining beam is blown up.

The ASACUSA experiment uses RFQD (Radio Frequency Decelerating Quadrupole) for further deceleration of antiprotons down to about 100 keV kinetic energy. The use of RFQD allows to reduce significantly beam losses in degrader because much thinner one can be used. Still the deceleration efficiency in RFQD is about 25% to 40% only and beam emittances are increased.

EXTRA LOW ENERGY ANTIPROTON RING (ELENA)

Machine Main Features and Location

For efficient deceleration of antiprotons to low energy a small ring with electron cooling has been proposed [3]. The low energy limit for this machine is 100 keV. It was chosen as a compromise between requirements from experiments of ultra low energy beam and constraints given by space charge limitations in machine and cooler, requirements to vacuum of few 10^{-12} Torr and others. The availability of electron cooling system allows to keep very high phase space density which is a top priority from users. With extra ring which delivers very dense low energy beam one to two order of magnitude more trapped antiprotons expected for experiments.

ELENA ring is a small machine with circumference of 26m and can be placed inside of AD Hall (see Figure 3). Small reshuffle of experimental area is required, as well as movement of some of AD equipment and new configuration of shielding. The precise positioning of a new ring in AD Hall will be dictated by optimal conditions for injection and for extraction into existing experimental areas.

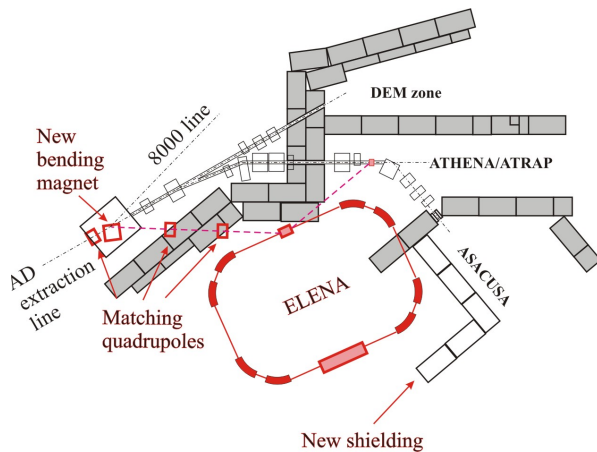

Figure 3: ELENA ring location in AD Experimental Area.

Ring Configuration

Two variants of ring configuration have been studied, triangular and rectangular [4]. For the first one possible tune range is from 0 to 1.5 and optics with suitable beta functions and working point $Q_x/Q_y=1.30/1.28$ can be prepared. For the second one tune range is from 0 to 2 and more choice of working points is available. The comparison of two optics shows that triangular machine is longer and provides less room in tune diagram which is essential due to space charge limitations at low energies.

As result, a machine with four straight sections has been chosen. Two long sections are suited for electron cooler and injection/ejection system, and two short

sections for beam diagnostics, RF equipment and other (Figure 4).

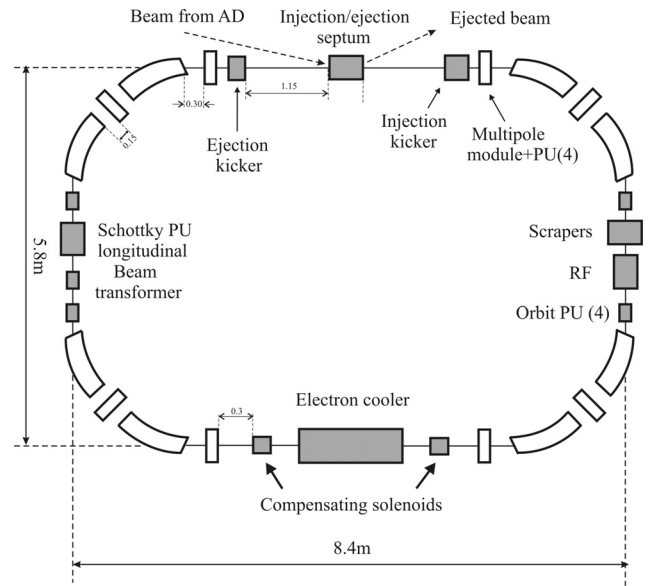

Figure 4: ELENA ring layout.

Electron Cooler

In ELENA cooling will be done at two momenta during deceleration cycle. At the intermediate momentum of 35 MeV/c the antiproton beam will be cooled to avoid beam losses during deceleration and to prepare good conditions for last cooling at 13.7 MeV/c. At extraction energy beam with small emittances is prepared by cooling to fit requirements for physics.

For fast and efficient cooling special attention must be paid to the design of the electron gun and the quality of the longitudinal magnetic field guiding the electrons from the gun to the collector [5]. The electron gun has to be designed in a way to produce a cold ($T_{\perp} < 0.1$ eV, $T_{\parallel} < 1$ meV) and relatively intense electron beam ($n_e \approx 3 \times 10^{12}$ cm $^{-3}$). The gun is immersed in a longitudinal field of 700 Gs which is adiabatically reduced to maximum field of 200 Gs in the transition between the gun solenoid and the toroid. Due to this transverse temperature is reduced as well during beam adiabatic expansion. The main characteristics of the proposed device are summarized in Table 5.

Table 5: Main parameters of electron

Cooling length, m	1
Beam cooled at momentum, MeV/c	35 and 13.7
Electron beam energy, V	355 and 54
Electron beam current, mA	15 and 2
Magnetic field in solenoid, Gs	200
Electron beam radius, cm	2.5

To compensate coupling introduced by drift solenoid, two compensators are placed on each sides of the cooler.

Two horizontal and two vertical orbit correctors are located on each side of the cooler for compensation of kicks produced by toroids and for optimal alignment of antiproton beam with respect to electron beam. The schematic layout of electron cooler for ELENA is shown in Figure 5.

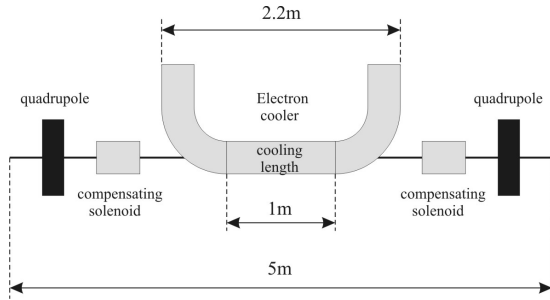

Figure 5: Layout of electron cooler for ELENA.

The simulation of electron cooling have been performed using BETACool code[6] to study sensitivity of cooling time to main cooler parameters like electron beam temperatures, magnetic field in drift solenoid and others. With electron beam parameters mentioned above and magnetic field 200 Gs the beam is cooled from $\epsilon_{x,y} = 20\pi$ mm mrad to $\epsilon_{x,y} = 1\pi$ mm mrad in one second. The influence of other parameters (gas pressure, IBS) has been studied as well [7]. Due to very strong optics perturbation by solenoidal fields operation with lower magnetic field (i.e. 150 Gs) is foreseen. With proper gas pressure required final emittances are achieved in a bit longer time, which makes no effect on ELENA performance because AD cycle is much longer than ELENA cycle.

Optics of ELENA

The machine optics was designed [4] to fit the following tasks:

- Magnet system should be compact and minimizing expenses
- Operation with significant incoherent tune shift due to space charge should be foreseen
- Proper conditions for effective work of electron cooling system should be prepared, and unavoidable effects of cooler on antiproton beam carefully compensated.

Two lattices with tunes $Q_x/Q_y=1.45/1.42$ and $Q_x/Q_y=1.64/1.62$ have been compared. The first one provides moderate beta functions in cooler about 3m to 4m, the second one gives twice smaller beta function values there. As result, the first optics is much more sensitive to effect of solenoid of electron cooler and of compensating solenoids, which increases toward the end of the ramp. This effect is squared with magnetic field in a drift solenoid of cooler and breaks lattice periodicity (Figure 6). On the other side, very small beta function values in a cooler section of the second optics are not favourable for fast cooling, which could be critical at low energy. In addition, in the first machine tunes are more

distanced from the limiting resonances. As result, the first variant of optics has been chosen.

The tune shift produced by electron beam is noticeable as well, but is much smaller than effect of solenoidal fields. It is independent on antiproton beam energy and can be handled more easily.

The important feature of optics is that focussing is done mainly in bending magnets by proper choice of length and edge angle. The quadrupoles are weak and suited for fine adjustment of tunes in operation, and for compensation of the effects of electron cooler on machine optics. Their location in a ring with respect to bending magnets is chosen to provide best efficiency.

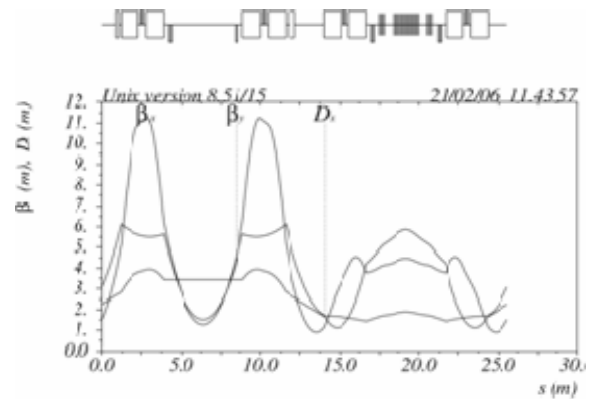

Figure 6: ELENA optics at extraction energy (effects of electron cooler and electron beam are taken into account).

Magnet System

To save space special magnet design has been proposed [8]. A horizontal and vertical dipole, normal quadrupole, skew quadrupole and sextupole are integrated into one module. The low level of required field allows to use normal conducting ironless magnets. The proper configuration of coil sectors is chosen (Figure 7) with homogeneous current density.

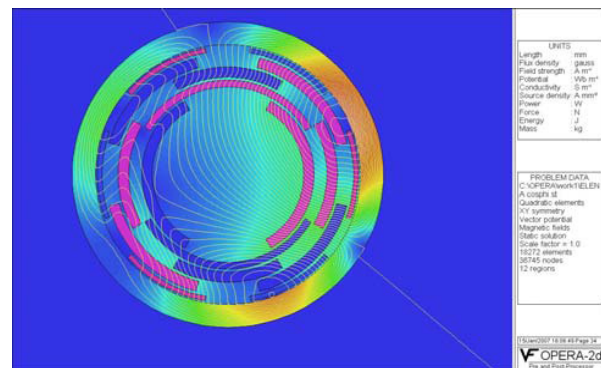

Figure 7: Multipole corrector.

All 8 modules are identical to reduce costs, but some of them may not be used, hence not connected to power supplies.

Beam Diagnostics

Eight horizontal and eight vertical PUs are foreseen to measure beam orbit. For beam intensity of 10^7 antiprotons in the bunch a resolution of 0.2mm (which is similar to AD) is expected.

An ultra low noise longitudinal Schottky PU which is a part of low level RF system [3] will be used for beam intensity measurements and for monitoring of longitudinal cooling. Signals from two units (low frequency and high frequency) are summed in an amplifier with appropriate equalizers to ensure the wide bandwidth required for intensity measurements. The transverse emittances will be measured with scrapers and scintillators.

Vacuum System

An ultra high vacuum of a few 10^{-12} Torr is required in the ELENA ring. The achieved pressure will define beam lifetime which is especially critical at low energies. Ultimate electron cooling is limited by residual gas scattering as well. To fit requirements vacuum chamber will be fully bakeable and coated with NEG. Ions pumps will be installed in cooler section.

ELENA Main Parameters

The main machine parameters are given in Table 6. The intensity limitation by space charge is calculated for bunched beam at 100 keV right before extraction. The bunch length is small at the end of bunch rotation and during time needed for synchronization with ejection kicker, typically a couple of hundred msec.

Table 6: Main parameters of ELENA

Energy range, MeV	5.3 – 0.1
Circumference, m	26.062
Emittances at 100 keV, π mm mrad	5 / 5
Intensity limitation by space charge	$1.1 \cdot 10^7$
Maximal incoherent tune shift	0.10
Bunch length at 100 keV, m / nsec	1.3 / 300
Expected cooling time at 100 keV, sec	1
Required vacuum* for $\Delta\varepsilon=0.5\pi$ mm mrad/sec, Torr	$3 \cdot 10^{-12}$
IBS blow up times for bunched beam* ($\varepsilon_{x,y}=5\pi$ mm mrad, $\Delta p/p=1 \cdot 10^{-3}$), s	1.1/- 9.1/0.85
* No electron cooling is assumed	

CONCLUSION

The AD is operating for physics since 2000 delivering more than $3 \cdot 10^7$ antiprotons per shot every 100 seconds

with emittances less than 1π mm mrad and bunch length about 170 nsec. The deceleration efficiency is above 80% due to good performance of stochastic and electron cooling systems. The number of antiprotons used for AD physics could be increased in one to two orders of magnitude with new small ring where further beam deceleration down to 100 keV kinetic energy will be performed together with beam cooling aimed on preparation of antiproton beam with high phase space density.

ACKNOWLEDGEMENTS

The author would like to thank the members of the AD team and CERN supporting personnel, whose contributions provide a machine with good operation and maintenance. Many people contributed to ELENA studies, particularly from operation, beam instrumentation, vacuum, RF, power converters, injection and ejection groups, and members of AD physics community. Thanks to all of them.

REFERENCES

- [1] S.Maury e.a., "Commissioning and First Operation of the Antiproton Decelerator (AD)", Proceedings of the 2001 Particle Accelerator Conference, Chicago, June 18-22, 2001, p.580.
- [2] P.Belochitskii, "Report on Operation of Antiproton Decelerator". The International Workshop on Beam Cooling and Related Topics (COOL05), Eagle Ridge Resort and Spa, Galena, IL (USA), September 18 - 23, AIP Conf. Proc.: 821 (2006) pp.48-56.
- [3] T.Eriksson (editor) e.a., "ELENA – a preliminary cost and feasibility study", to be published.
- [4] P.Belochitskii, "ELENA optics", private communication.
- [5] G.Tranquille, "Electron cooler for ELENA", private communication.
- [6] I.N.Meshkov e.a. "Simulation of electron cooling process in storage rings using BETACOOOL program", in: Proceedings of beam Cooling and Related Topics, Bad Honnef, Germany, 2001.
- [7] P.Belochitskii, "Simulation of electron cooling in ELENA ring with BETACOOOL", private communication.
- [8] P.Belochitskii, T.Eriksson, Th.Zickler, "Magnet Design Proposal for ELENA and the Injection Transfer Line", AT-MEL Technical Note (to be published).